

__Model__ CSV1 and CSV1.25 Pump Control Valve

Installation Instructions

NOTE: Submersible motor manufacturers recommend using a flow inducer sleeve to be sure the motor is sufficiently cooled at low flows.

Please read all instructions before beginning installation.

- 1) Be sure that the well has been pumped clean before any valve installations. It is also important that all lines including the pump be flushed clean of debris. Pipe dope or trash pumped into the valve will make it weep. Turn off power to pump and drain system.
- 2) The valve should be installed downstream of the pump on the pump side of the pressure tank/pressure switch with any and all water outlets downstream of the valve. Flow direction is indicated by an arrow on the side of the valve. (Note: There cannot be any water outlets between the pump and the valve..ie pressure relief valves, frost free hydrants, etc. If any outlet lines are located between the well and the pressure tank, the valve must be installed at the well head or in the well using the CSC coupling.)
- 3) **Model CSV1 or CSV1.25** should be **hand tightened** using Teflon tape on threaded ends. Four to seven wraps of Teflon tape is usually sufficient. **Do not use pipe dope as it can run into the valve works.** All connections should be water tight. If using galvanized unions, be careful not to overtighten as that will cause the valve to separate at the center and leak.
- 4) The pressure tank should be installed on a tee at a 90E angle to the main discharge line downstream of the of the CSV1. Pressure switch and other controls must be installed as close to the tank as possible. Pre-charge pressure in the tank should be 5-10 PSI lower than pressure switch start point.
- 5) For use with small pressure tanks (5 GPM drawdown or less), set pressure switch start pressure the same as the Cycle Stop valve pressure (For example, CSV140 should use a pressure switch set at 40/60). When using larger tanks (6 GPM drawdown or more), set the pressure switch to its highest setting by turning the tall screw clockwise as far as possible, close off downstream use, wait a minimum of 2 minutes as the tank fills, turn tall screw on your pressure switch counterclockwise until the pump is turned off.

California Proposition 65 Warning
This product contains chemicals known to the state of California to cause cancer and birth defects or other reproductive harm. (Installer: California law requires that this warning be given to consumer.)

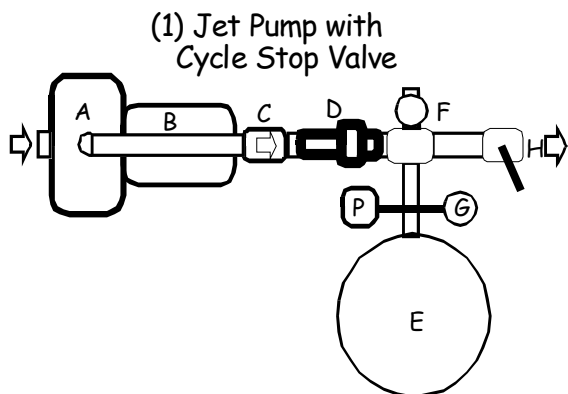

- A) Pump
- B) Motor
- C) Check valve
- D) Cycle Stop Valve
- E) Pressure tank
- F) Pressure relief valve
- G) Pressure gauge

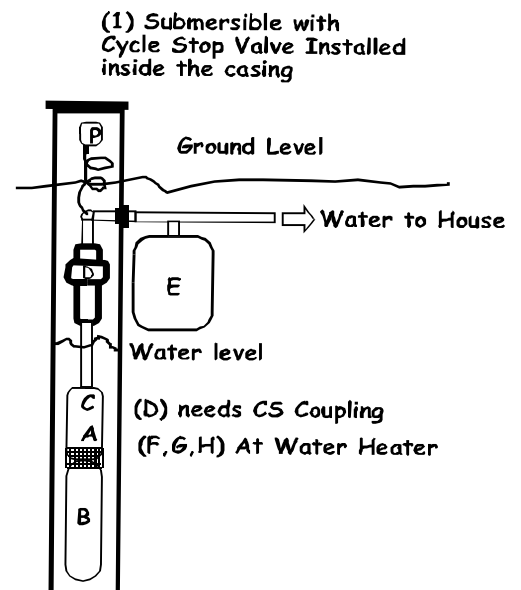

(1) Submersible with
Cycle Stop Valve Installed
inside the casing

Ground Level

Water level

(b) needs CS Coupling
(F, G, H) At Water Heater



CSV1 and CSV1.25 Troubleshooting

Symptom

Cause

Remedy

Pump is Cycling off and on

Bad or torn diaphragm

This is usually due to back pressure being higher than 150 PSI. You will have to change models to a CSV1Z if this is the case. Replace valve.

Pressure switch not set correctly

Cut off pressure must be higher than valve pressure. Reset pressure switch cut off to at least 10 psi higher than valve pressure.

Waterlogged pressure tank

Replace tank

Low pressure

Demand is more than pump can provide at desired pressure

Reduce demand so it is within pump capabilities to maintain desired pressure.

Check psi marking on valve

Switch to correct model valve

Chattering valve

Too much air pressure in tank

Reduce air pressure in tank to 5-10 PSI below cut in pressure.

Pump rapid cycles at start up and then begins to function correctly

Pressure switch is located on the main line or closer to the main line than the pressure tank.

Move pressure switch to small line at the base of the tank on a line no larger than 1 1/4" in diameter

CSV setting is too close to cut off pressure

Set pressure switch cut off pressure at least 10 PSI higher than CSV setting

Air pressure in tank too high

Reduce air pressure in tank to 5-10 PSI below cut in pressure

Multiple check valves in system working against each other

Remove all but the check valve or foot valve on the pump itself